

Series T95 LA

**Folded shear beam load cell for
high accuracy weighing**

capacities 2 t to 20 t



Stainless steel load sensor

Auto-phoretic coated loading assembly

Fully welded construction sealed to IP68

year warranty

Ease of installation

Integral lift off prevention

Load cell is always in tension

Ideal in vibrating applications

OIML C3 alloy steel approved version

Unique damping feature

The T95 range comprises of a stainless steel load cell complete with toughened auto-phoretic finish loading assembly. Although the assembly is used in compression, the cell is mounted in a pendulum and operated in tension. This ensures that the load point is always maintained through the central axis of the cell, even when the assembly is subjected to considerable movement or misalignment.

The T95 LA is most suitable for high accuracy applications and where movement or vibration are present. eg. mixers, catalyst vessels, weighing platforms and axle weighers. It is also available with intrinsically safe certification ATEX EEx ia IIC T6, certified for use in both Gas and Dust Zones. Ex nA II T6 Gas only certification is also available which allows zone 2 use without safety barrier.

technical specification sheet

Series T95 LA

	Accuracy Class		Units
	Commercial	C3#	
Capacities 2,000 5,000 10,000 & 20,000kh	Commercial	C3#	
Rated Output	2	2	mV/V±0.25%
Combined Error	<±0.05	In accordance with OIML R60	%*
Non-repeatability	<±0.02		%*
Temperature Effect on Zero Balance	<±0.0025		%*/°C
Temperature Effect on Span	<±0.0035		%*/°C
Compensated Temperature Range	-10 to +40		°C
Operating Temperature Range	-40 to +80	-40 to +80	°C
Safe Overload	150	150	%*
Ultimate Overload	300	300	%*
Zero Balance	< ± 1	< ± 1	%*
Input Resistance	380	380	Ω ± 30
Output Resistance	350	350	Ω ± 1.5
Insulation Resistance	>5000	>5000	MΩ @ 100v
Recommended Supply Voltage	10	10	V
Maximum Supply Voltage	15	15	V

*With respect to rated output

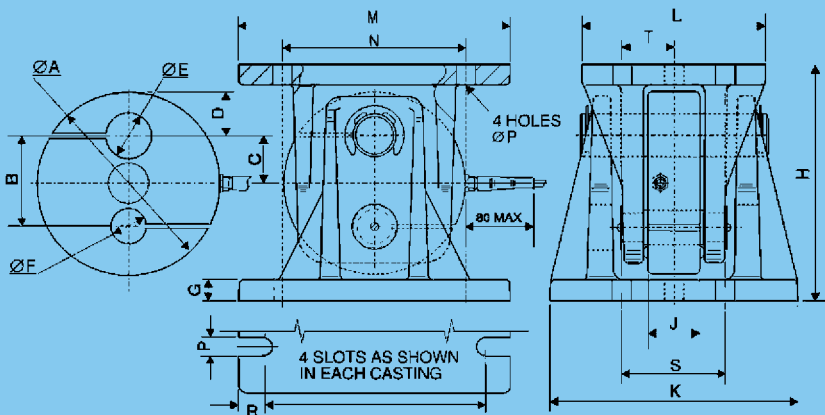

Range (kg)	A	B	C	D	E	F	G	H	J	K	L	M	N	P	Q	R	S	T
2000 - 10000	134	66	35	32	32.5	26	15	174	38	182	135	200	135	16	170	15	70	35
20000	187	87	40.5	53	48	36	22	245	57	252	186	260	185	20	218	21	100	50

All dimensions in mm.

Note: Cell performance is characterised when tested in the specified loading assembly

Electrical Connections

Via 4 core, 10m, (20m for 20000kg model), 6mm dia., screened polyurethane cable.

Screen not connected electrically to load cell.

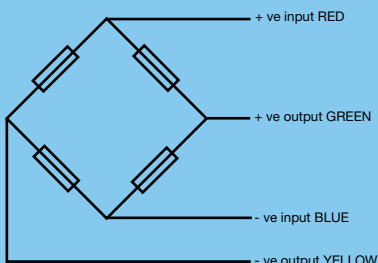

Shipping Weights: (kg)

Cell = 4 (10000), Cell = 11.5 (20000)
LA 95 = 14 (10000), LA95 = 38.5 (20000)

Construction

Load Cell manufactured from 17-4PH stainless steel heat treated to H900 condition - 1379N/mm² UTS.

Options

#For C3 applications there is an alloy steel version available.

Our policy is one of continuous product enhancement. We therefore reserve the right to incorporate technical modifications without prior notification.

Distributed by

Wessex Scale Co
Lower Mill, Exford Nr Minehead
Somerset TA24 7QE
Tel: 0845 472 5345
Fax: 01643 800 299
Email: sales@wessexscales.co.uk
Website: www.wessexscales.co.uk

