



TECHNICAL DATA

- ◆ External resolution.....1/30,000(QHW)
- ◆ Display.....24mm backlit LCD
- ◆ Pan size.....230mm×300mm
- ◆ Keyboard.....7 keys embossed membrane keyboard
- ◆ Operate temp.....0°C ~ +40°C
- ◆ ADC.....sigma delta
- ◆ ADC update.....≤ 1/10 second
- ◆ Internal counts.....600,000
- ◆ Rating.....Mains lead and
Internal rechargeable battery (6V/4Ah)

FEATURES

- ◆ 24mm digits high LCD backlit display
- ◆ Function include check weighting, counting, percentage, accumulate and weighing units conversion
- ◆ Rechargeable battery operation
- ◆ Check weighing function (user can set hi/low limit for weighing, counting and percentage)
- ◆ Auto backlight display
- ◆ RS-232C communication port

DIMENSIONS (mm)

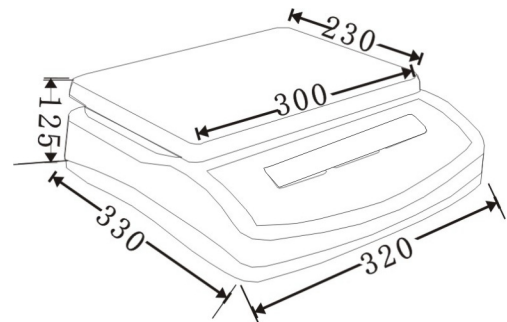

SPECIFICATIONS

MODEL	QHW-3		QHW-6		QHW-15		QHW-30	
Capacity	3kg		6kg		15kg		30kg	
Readability	0.1g		0.2g		0.5g		1g	
Tare range	3kg		6kg		10kg		30kg	
Pan size	230mm x 300mm							
Gross weight	5.1kg							

Models and specifications subject to change without notice

Supplied by,

Wessex Scale Co, Lower Mill, Exford Nr Minehead Somerset TA24 7QE
 Tel: 0845 472 5345 Fax: 01643 800 299 Email: sales@wessexscales.co.uk
 Website: www.wessexscales.co.uk