



Model EB Series

Compact Bench Scale



The Ohaus EB Series Compact Bench Scale – Utility, Portability, Ohaus Quality and Value.

Weigh, count, checkweigh, checkcount, percent weigh - the Ohaus EB Series Scale is a multi-function weighing scale designed as a cost-effective, high-performance equipment for a multitude of light to medium industrial applications. With fast and accurate displayed results, multiple functionality and internal battery operation, the Ohaus EB Series offers versatility, portability and dependability in one affordable package.

Standard Features Include:

- Popular capacity models: 3kg, 6kg, 15kg, 30kg
- Readabilities from 0.1g to 1g, depending on model
- Maximum displayed resolution of 1:30,000
- Durable plastic housing with clear in-use cover
- Stainless steel weighing pan
- High contrast backlit LCD display with prominent 25mm high digits
- Fast display \leq 2 seconds
- Four weighing units: kg, g, lb and oz
- Dedicated TARE key for simple and fast operation
- Accumulation function for weight and parts count
- Application modes: Check-weighing/counting, Count and Percent
- User-programmable weight and parts HI/LO checking mode with audible buzzer
- Adjustable filtering level for weighing under various conditions
- 80-hour Internal rechargeable battery with power-saving Auto-shut off feature
- Industry leading quality and support

The Ohaus EB Compact Bench Scale

Specifications

Model	EB3	EB6	EB15	EB30
Capacity x Readability	3000 g x 0.1 g	6000 g x 0.2 g	15000 g x 0.5 g	30000 g x 1 g
Maximum Displayed Resolution	1:30000	1:30000	1:30000	1:30000
Construction	Stainless steel pan, plastic housing			
Weighing Units	kg, g, lb, oz			
Application Modes	Weighing, Counting, Hi-Lo Check-weigh/count, Percent, Accumulation			
Repeatability (std. deviation)	1d			
Linearity	± 1d			
Display	1-Window backlit LCD display, 25.4 mm High, 6-digit, 7-segment			
Display Indicators	Stability, Center of Zero, Gross, Tare, Battery status, Hi-Ok-Lo, Units			
Hi-Lo Check Indicators	Display with Alert beeper			
Keyboard	7 Raised Tactile Membrane switches: M+, Units, Zero, Tare, Check, Count, %			
Zero Range	4% of Full Scale Capacity			
Tare Range	Full Capacity by Subtraction (except EB15, up to 10kg only)			
Stabilization Time	≤ 2 seconds			
Operating Temperature	0° to 40°C / 32°F to 104°F			
Humidity Range	≤ 90% relative humidity, non-condensing			
Power	AC Adapter 12V DC / 800mA Internal rechargeable sealed lead acid battery			
Battery Life	80 hours continuous use with 12 hour recharge time			
Calibration	Automatic external with kg/g mass, factory calibration recovery			
Shipping Protection	Shipping screw to avoid damage to sensitive components			
Safe Overload Capacity	120% of capacity			
Pan Size	294 x 226 mm			
Scale Dimensions	325 x 330.5 x 114 mm			
Shipping Dimensions	440 x 360 x 160 mm			
Net Weight	4.2 kg			
Shipping Weight	5.3kg			
Other Features	Auto-Zero Tracking, Filtering Level			

Outline Dimensional Drawings

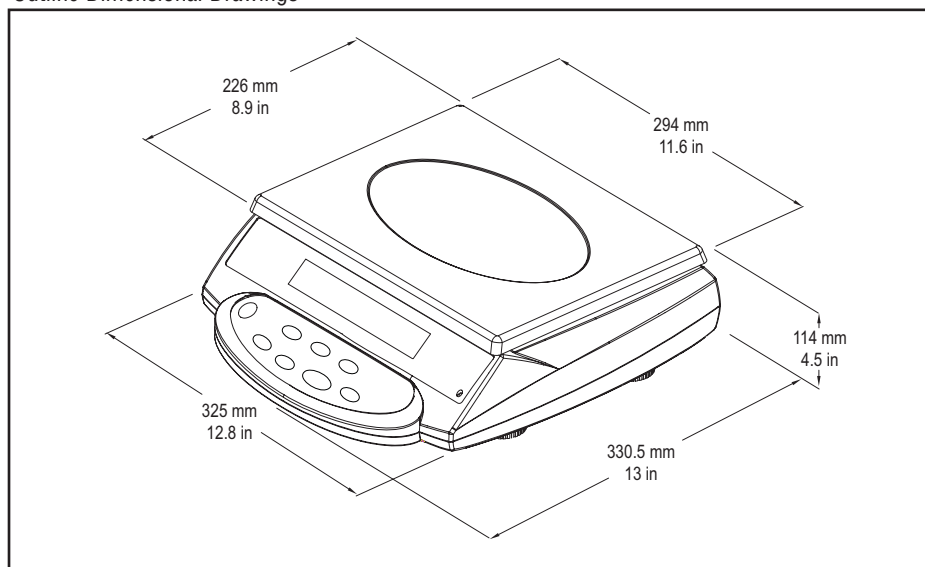

Supplied by,

Wessex Scale Co, Lower Mill, Exford Nr Minehead Somerset TA24 7QE
Tel: 0845 472 5345 Fax: 01643 800 299 Email: sales@wessexscales.co.uk
Website: www.wessexscales.co.uk

80774226 © Copyright Ohaus Corporation

*ISO 9001:2000
Registered Quality Management System

