

H303

Wessex Scale Co

carcass scale



space-saving carcass weigher for any business

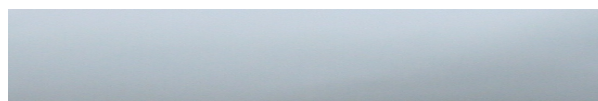

space-saving carcass weigher for any business

Avery Berkel has designed the **H303** scale to bring faster, more accurate carcass weighing to any business - from the independent butcher or supermarket to the abattoir or meat processing factory.

In addition to its versatile design, the **H303** combines the benefits of the latest digital weighing technology with the advantages of stainless steel construction.

◆ Compact design

One of the major benefits of the H303 is its compact design, making it ideal for use where space is at a premium. It features a wall mounted weigh platform which can be folded back and occupies less room than a conventional free standing or bench mounted platform.

◆ Versatile

The stainless steel platform can be used independently of the pillar and hook, as a convenient wall mounted bench scale for weighing and checking pre-packed and boxed goods. This can be folded away and held in place by a safety catch, allowing access to a stainless steel hook for quicker and easier carcass weighing.

◆ Maximum hygiene

Designed to maximise hygiene and make cleaning as easy as possible, the **H303's** weigh platform, pillar and hook are manufactured entirely in food grade stainless steel, hoseproof to IP65.

The mounting bracket and wallplate are finished in food industry standard galvanised mild steel, while the platform itself features a smooth brushed surface to allow easy wipe over cleaning and to prevent particle build-up.

An optional stainless steel backplate is also available to prevent any splashes or food debris falling behind the pillar.

◆ Quick and easy installation

The **H303** is supplied ready calibrated allowing quick and easy installation by an engineer to customer's instructions.

Dimensions

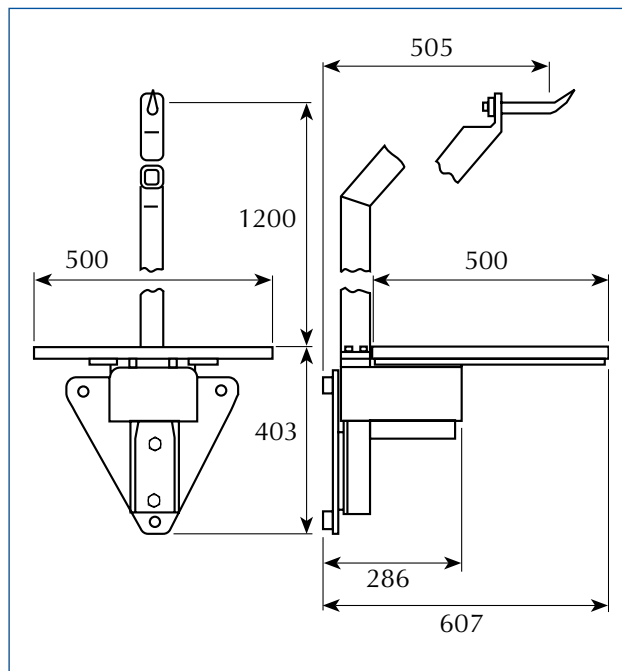

◆ Variety of capacities

This versatile scale is available in a variety of capacities to suit the needs of your business. Standard capacities include 60 kg and 150 kg while for larger carcass, a 200 kg version is available.

◆ Range of indicators

Depending on your requirements, the H303 can be connected to an extensive range of Avery Berkel electronic indicators. These include a variety of advanced, basic, waterproof and remotely sited weight displays.

◆ Economical Option

The H303 is available with a nylon coated pillar as an economical alternative to the stainless steel model.

© Avery Weigh-Tronix 2003. All rights reserved. This publication is issued for private and information only which, unless agreed by Avery Weigh-Tronix in writing, may not be regarded as a representation relating to the product or service. Avery Weigh-Tronix reserves the right to alter without notice the specification, design, price of the product or service.

Supplied by: Wessex Scale Co, Lower Mill, Exford, Nr Minehead, Somerset TA24 7QE
Tel: 0845 472 5345 Fax: 01643 800 299 Email: sales@wessexscales.co.uk
Foundry Lane, Smethwick, West Midlands, England B66 2LP
Tel: +44 (0)870 90 34343 Fax: +44 (0)121 224 8183

Website: www.wessexscales.co.uk

E mail: info@awtxglobal.com

Internet: <http://www.averyweigh-tronix.com>

Avery Weigh-Tronix